

Grippex® II - Instructions for disassembling / assembling of fingers

Remark: The new fingers can be mounted using this instruction backwards.

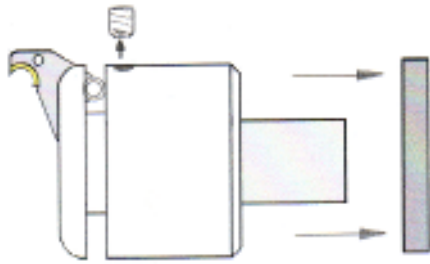

1. Unscrew the Valve-screw and remove the cover.

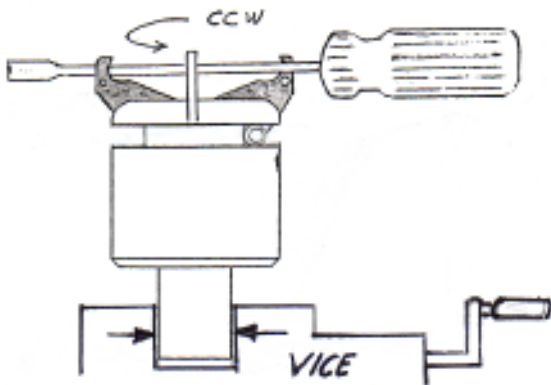

2. Demount the inserts from the fingers. Set up Grippex in a vice and clamp on the shank. Use a screwdriver and turn the body ccw and the body will be loosen from the shank.

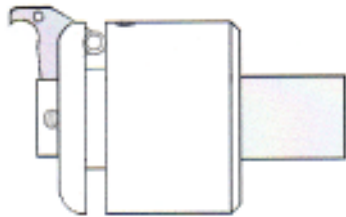

3. Turn the body c.c. approximately 4 turns. Now the three holes ($\varnothing 4$ mm) on the shaft will be visible nearly up to full. Don't turn it too long, otherwise the pins will fall out. If the shaft doesn't come out automatically, hit the shank a little.

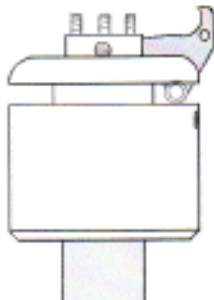

4. Unscrew the three screws (M4x8 mm) on the shank till the cylindrical pins can pass and be put aside.

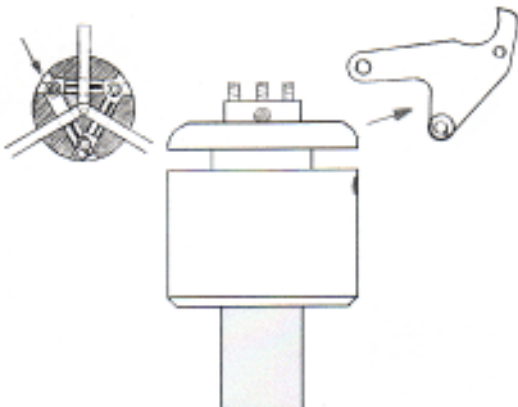

5. Put the pins aside and the fingers will be released and can be removed.